

# AIRPHX

## IDU 250K User & Installation Guide

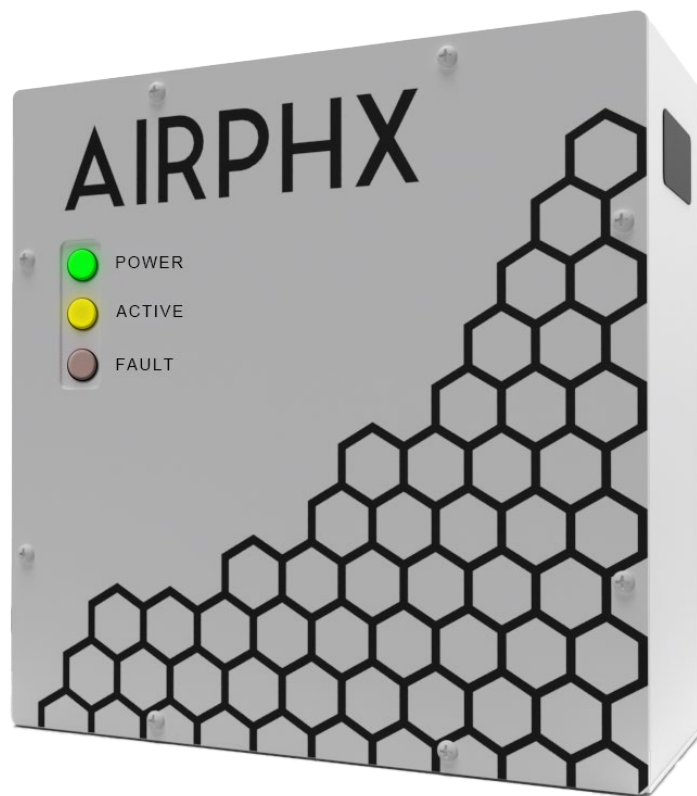

Rev 1.0 • Jan, 2023

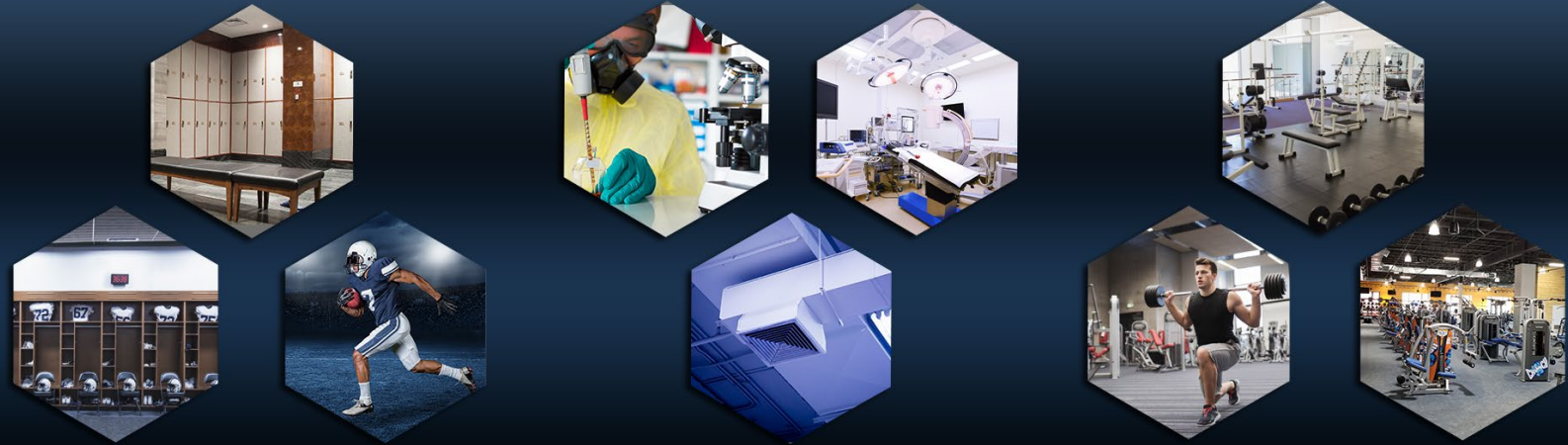

## Important Safety Instructions



1. CAUTION: The IDU 250K contains a plasma core with a glass element. Please handle it with care.
2. CAUTION: Do NOT install the IDU 250K if the unit has signs of damage. Doing so may put you at RISK OF ELECTRICAL SHOCK.
3. WARNING: Do NOT defeat the front cover interlocking switch. Doing so may put you at RISK OF ELECTRICAL SHOCK.
4. The IDU 250k is suitable for dry locations ONLY. Do NOT use outdoors, and do not expose to liquids. High moisture levels may damage the unit's plasma core.
5. WARNING: Do NOT modify the unit in any way. Doing so may put you at RISK OF ELECTRICAL SHOCK.
6. Modifying the unit will void the warranty.
7. WARNING. Do not remove the inner electronics cover. Doing so may put you at RISK OF ELECTRICAL SHOCK.
8. Use the provided mounting hardware or equivalent.
9. WARNING: Do not operate the unit if it has a damaged power cord. Doing so may put you at RISK OF ELECTRICAL SHOCK.
10. Do not stretch the power cord or place it under strain.
11. The use of an electrical extension cord is not permitted.
12. WARNING: Do not try to repair a damaged unit. Doing so may put you at RISK OF ELECTRICAL SHOCK.
13. WARNING: This equipment has a grounding-type plug with a third (grounding) pin to reduce electrical shock. This plug will only fit into grounding-type power outlets. If the plug does not fit into the outlet, contact a qualified person to install the proper outlet. Do not alter the plug in any way.
14. WARNING: An electrostatic air filter should be installed before the fan and heating source. Do not install an electrostatic air filter in the direct hot air current from a heater. N'installez pas un filtre a air dans un courant d'air chaud direct d'un appareil de chauffage.

### Note:

This product complies with the maximum allowable concentration of ozone of 0.050 parts per million by volume (ppmv) in a 24-h period.

The 8-hr TWA Ozone for this product is 0.000 ppmv when tested in a 30 m3 chamber

# Contents

Important Safety Instructions.....	2
1 Overview.....	4
Specifications.....	5
Technology Overview .....	5
Oxidizing Molecules.....	5
2 Unit Overview .....	5
3 Pre-Installation Checklist .....	6
Recommended tools.....	6
Included in the box .....	7
4 Installation Prep.....	8
5 Installation Overview – Unit Placement.....	8
6 Installation Overview – Unit Dimensions.....	9
7 Installation - Disassembly Procedure.....	10
Removal of the Front Cover.....	10
Removal of the plasma core .....	11
8 Installation Procedure.....	11
Unit Mounting .....	11
Mounting Example - Fig. 1A.....	12
9 Installation - Reassemble Procedure .....	13
Plasma Core Reassembly .....	14
Installing front cover.....	14
10 Modes of Operation .....	15
Active Mode.....	15
Standby Mode .....	15
Conditions that can cause the IDU 250K to go into standby mode: .....	15
Fault.....	15
Conditions that can cause the IDU 250K to go into fault:.....	15
11 Operations & Controls .....	16
Power the IDU 250K on for the first time: .....	16
12 Controls/Indicators .....	16
On/Off Switch .....	16
13 Indicators.....	16

	Power Indicator .....	16
	Active Indicator .....	16
	Fault Indicator .....	16
14	Servicing - Filter Replacement Procedure.....	17
	Filter Location .....	17
	Filter cover Location - Fig. 1B.....	17
	Removing filters.....	18
	Filter Removal - Fig. 1C .....	18
15	Servicing - Plasma Cell Replacement Procedure.....	19
	Plasma Core Cover Removal - Fig. 1D .....	19
	Plasma Cell Removal - Fig. 1E .....	20
	Plasma Cell Replacement - Fig. 1F .....	20
	Plasma Cell Replacement - Fig. 1G.....	21
16	Indicator Reference Guide.....	22
17	Annunciator Overview (optional) .....	23
	.....	23
18	Annunciator Installation .....	24
	Steps .....	24
19	Annunciator Connection .....	25
	Steps .....	25
20	Troubleshooting Guide .....	26
21	Frequently asked questions.....	27
22	Frequently asked questions cont.....	28
	Warranty .....	29
	Disclaimer.....	31

## 1 Overview

This User & installation guide contains basic information for the safe installation and operation of the AIRPHX IDU 250K. The operation and installation of this equipment is the end user's sole

responsibility. CAUTION: Please read this guide in its entirety before installing and operating the equipment.

## Specifications

Mounting Details	Induct application
Cutout size for duct	6 inches round hole
Mounting depth (into duct)	7.5 Inches
CFM	400 – 2,000
Minimum airflow (Linear feet per minute)	300 LMF*
Tonnage	2.0 – 10-ton unit
Power (VAC)	80-260
Frequency	50/60 Hz
Watts	120
AMPs	1.0 at 120VAC
Weight	5 lbs.
Height (enclosure)	9.5 inches
Width (enclosure)	9.5 inches
Depth (enclosure)	4 inches

\* The IDU 250K requires a minimum of 200 LFM to operate.

## Technology Overview

The IDU 250K produces a variety of oxidizing molecules that get generated as ambient air passes through the unit's plasma core. These molecules are carried by air within the duct system to the treatment area. This process treats the air within the duct and the air and surfaces within the treatment area. Using a built-in airflow sensor, the IDU 250K runs automatically, turning on when there is airflow in the HVAC system and turning off when there is no airflow.

## Oxidizing Molecules

The oxidizing molecules occur naturally in most environments, but AIRPHX produces them in a unique mixture and at extremely effective levels in killing germs and viruses. Because it requires no chemicals or liquid additives, the AIRPHX process is safe and certified to comply with UL 867 (the Standard for Safety for Electrostatic Air Cleaners), California's (CARB) stringent ozone emission standards, and Federal organic standards.

*Note: Coverage capacity can vary based on several factors, including duct layout, air circulation, damper controls, fresh air exchange rate, airflow, and bioburden. Contact an AIRPHX representative to discuss capacity at your particular location.*

## 2 Unit Overview

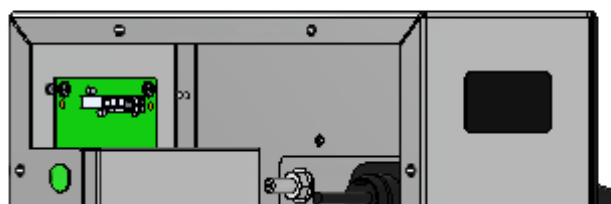

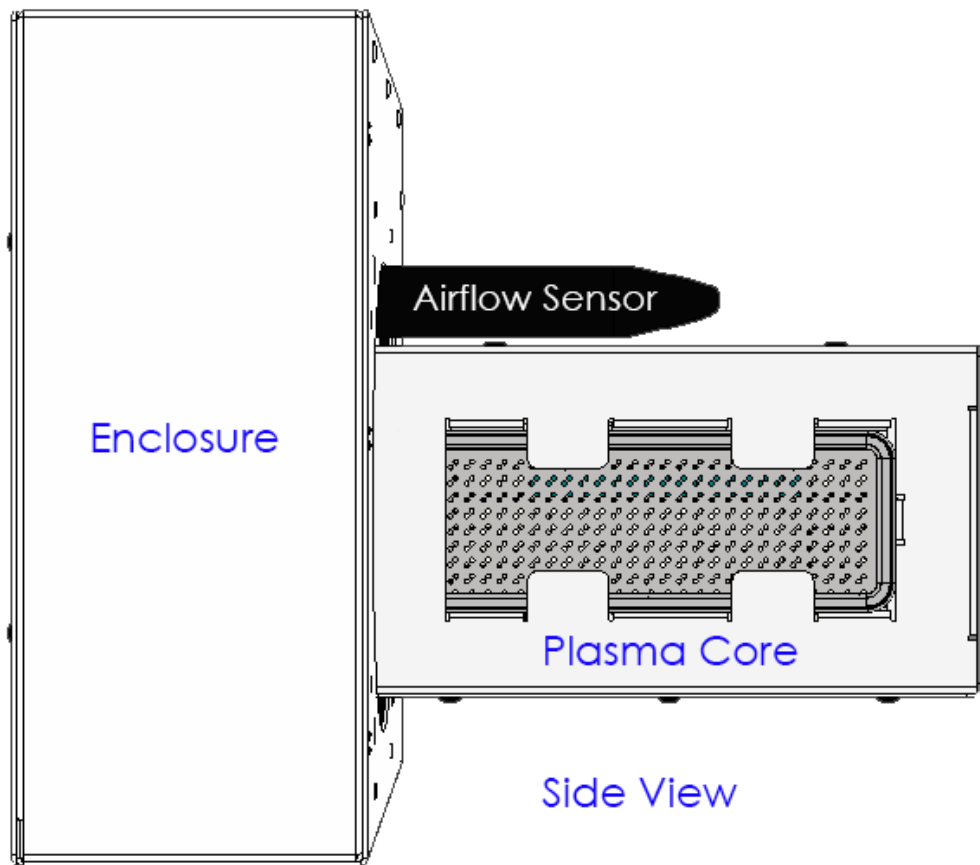

### 3 PRE-INSTALLATION CHECKLIST

#### Recommended tools

- Level
- Marker

- Phillips Screwdriver
- Punch
- 3/16" drill bit
- 6"-hole saw
- Painter's tape
- 7/16" deep socket
- 6" socket extension
- Ratchet
- Safety glasses
- Safety gloves
- Metal file

## Included in the box

- IDU 250K
- Mounting hardware
- Mounting template
- Gasket (affixed to unit)
- AC power cord (pre-attached to unit)
- IDU 250K Quick Reference Guide
- IDU 250K Quick Reference Card
- Welcome card
- Complete Indoor Disinfection decal

---

*Please follow all recommendations for the mounting and installation of the IDU 250K set forth in the User & Installation Guide available at [www.airphx.com/products](http://www.airphx.com/products). If you have any questions about the installation, please contact your AIRPHX representative at 855-424-7749 or visit our website <https://www.airphx.com/FAQs>, where additional information can be found.*

---

## 4 Installation Prep



- Find a location in a duct downstream of the system fan and filter.
  - Avoid locations with high humidity, like swimming pools, whirlpools, and showers.
  - Mount the unit at least 5 feet from a 90-degree bend.
  - Mount the unit at least 3 feet downstream of the HVAC system fan and filtration system.
  - CAUTION: Use the provided hardware or equivalent to secure the IDU 250K to the duct.
  
- WARNING: The IDU 250K requires a standard grounded 120-volt outlet.
  - Verify the voltage of the outlet before use.
    - The unit's amperage is around 1 amp on power at 120VAC. Therefore, it can be part of an existing circuit.
  - Please ensure that any newly installed 120- volt power outlet is a ground-type outlet and meets all local, state, and government electrical codes.
  - Verify that the outlet is not part of a circuit that may be overloaded. Large power fluctuations associated with overloaded circuits can damage the IDU 250K.
  - WARNING: The use of an extension cord is not permitted.
  
- The IDU 250K comes preassembled for shipping purposes; therefore, removing the front cover and the unit's plasma core will be necessary before mounting the unit. *Please refer to section 5, Disassembly, for further details.*
  
- CAUTION: The IDU 250k plasma core contains a glass element. Handle with care.

## 5 Installation Overview – Unit Placement

The IDU 250K works with the airflow within the HVAC duct system. Therefore, the IDU 250K must be mounted downstream of the HVAC system fan. Mounting the unit downstream will also place it downstream from any filtration system used in the HVAC system.



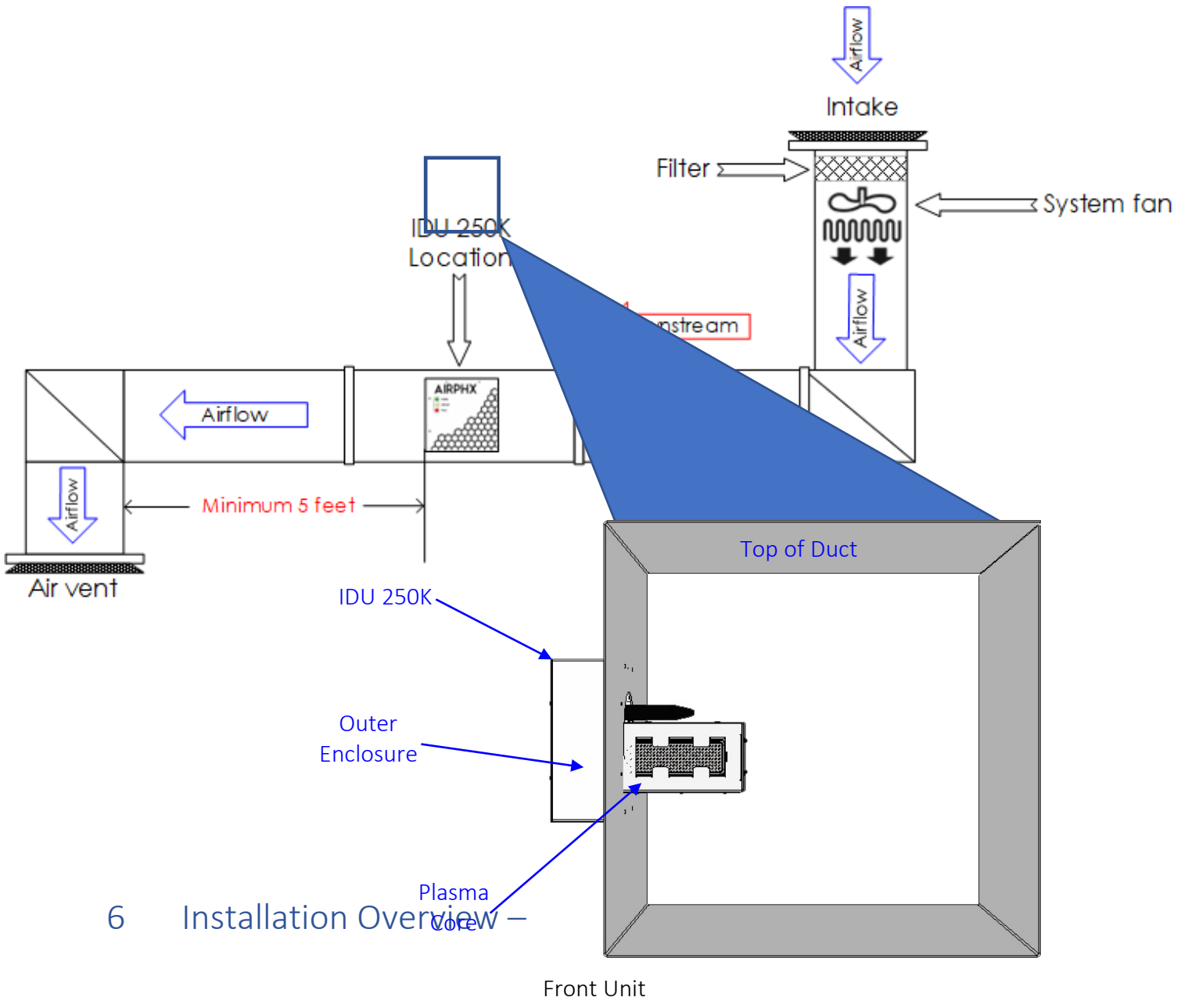

6 Installation Overview



Side of Unit

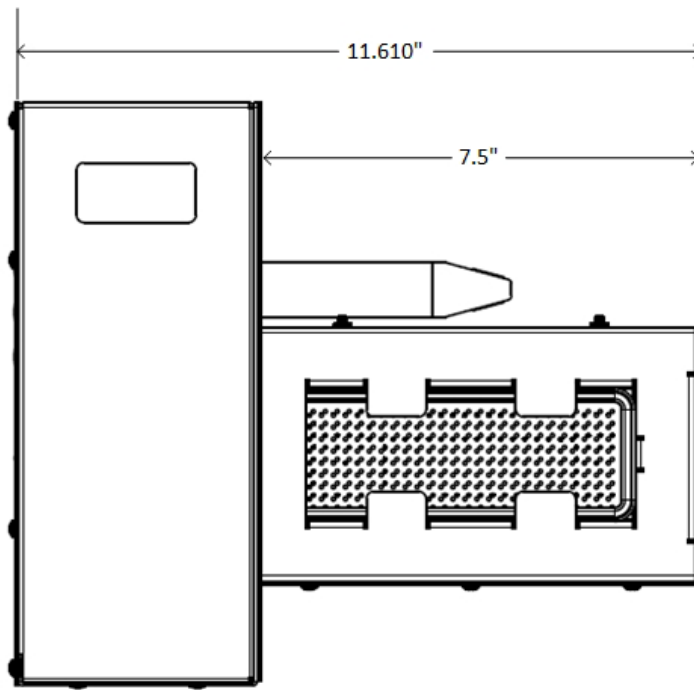

7 Installation  
Removal of the  
First, remove the 8

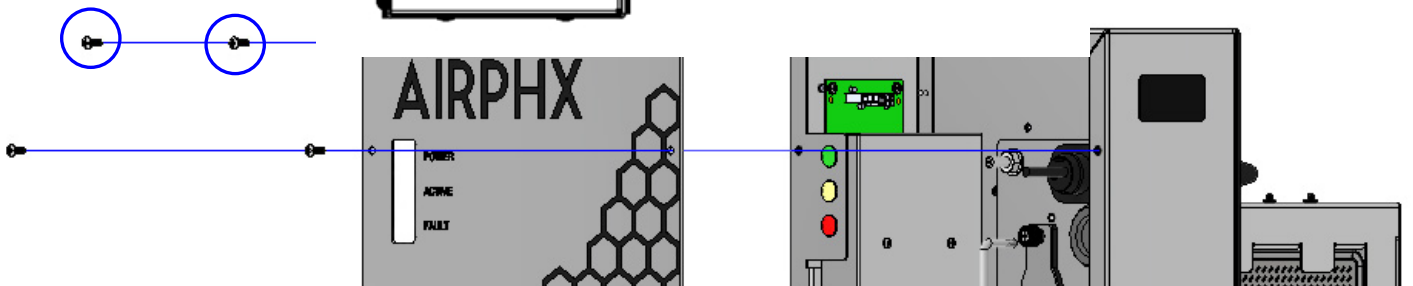

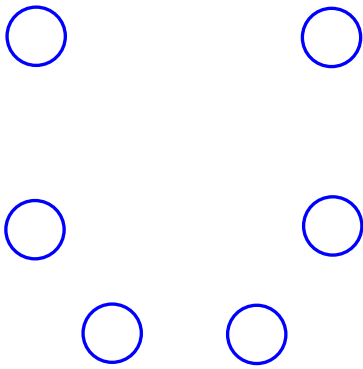

Cover

Enclosure

## Removal of the plasma core

Using a 7/16" deep socket with a 6" extension, remove the four 7/16" nuts from the threaded studs that secure the core to the enclosure.

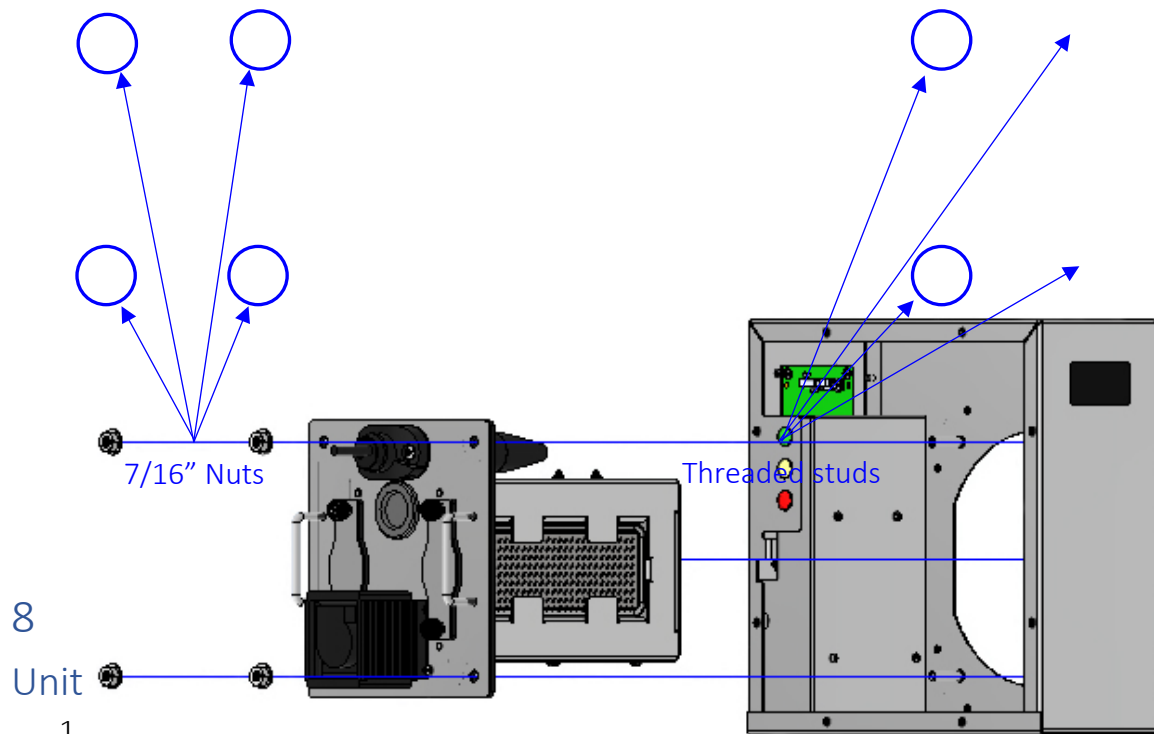

- 1.
- 2.
3. Using a punch, punch all eight mounting and the center holes.
4. Remove the mounting template and highlight the marks with a marker.
5. Using a drill with a 3/16" drill bit, drill all eight mounting holes.

6. Use a 6" hole saw and drill out the center hole. This 6" hole is for the IDU 250Ks plasma core that will recess into the duct.

*Helpful hints: When drilling the 6" hole.*

- *Go slow.*
  - *Use a drill with a lot of torque.*
  - *Set the drill to a low speed/ high torque setting.*
  - *Keep the hole saw flush against the metal surface while drilling to minimize the hole saw from grabbing the metal.*
7. CAUTION: Safety gloves are recommended as the 6" hole within the duct may contain sharp edges.
  8. Use a metal file to remove any sharp edges or burrs.
  9. Holding the enclosure in your hand, push one of the provided mounting screws through the enclosure and then through its pre-affixed mounting gasket. *See fig 1A (next page) for more details.*
  10. Holding the enclosure with a mounting screw protruding through the enclosure and gasket, push the screw through the duct and its corresponding hole.
  11. Using the center 6" hole as an access point, loosely thread one of the provided mounting nuts onto the screw. It may help to have an assistant hold the enclosure in place. Please use caution, as the edges of the hole may be sharp.
  12. Install all eight screws.
  13. Using a level, confirm that the IDU 250K is level before tightening all eight screws.
  14. Ensure the enclosure gasket is seated against the ductwork.

## Mounting Example - Fig. 1A

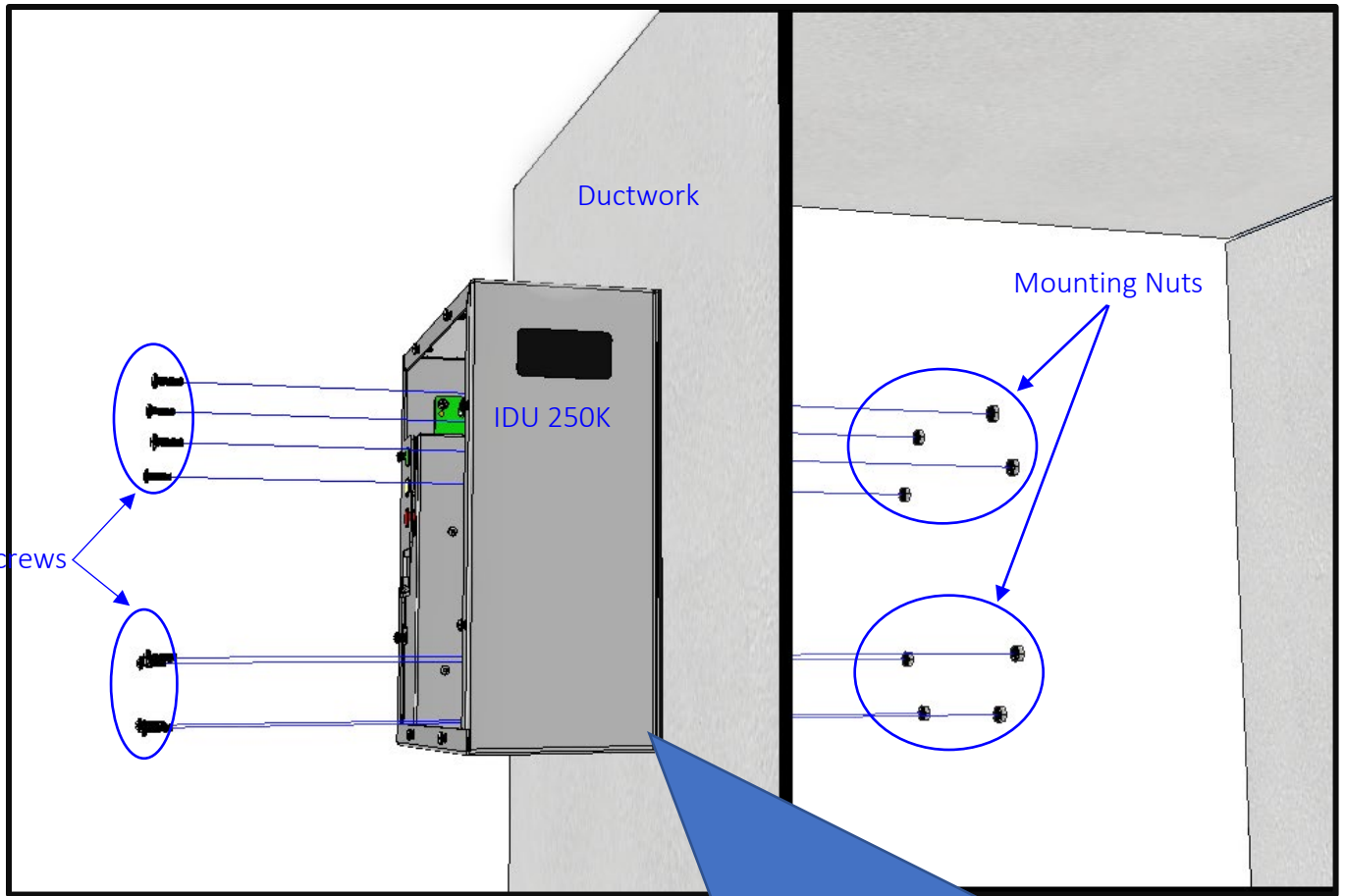

Note:

Use the 6" hole to access the nuts on the inside of the ductwork.

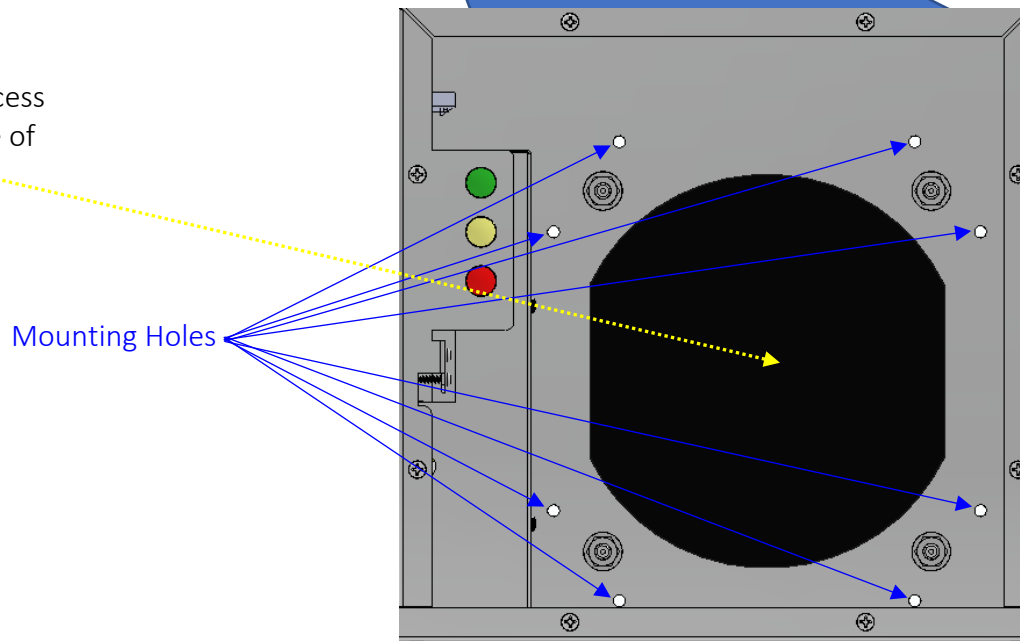

## 9 Installation - Reassemble Procedure

## Plasma Core Reassembly

1. Carefully insert the plasma core through the 6" center hole in the center of the enclosure and into the duct.
2. Holding the plasma core in place, loosely thread one of the 7/16" nuts.
3. Repeat step 2 until all four nuts are in place.
4. Using a 7/16" deep socket with a 6" extension, tighten all four nuts until the plasma core gasket is firmly seated.

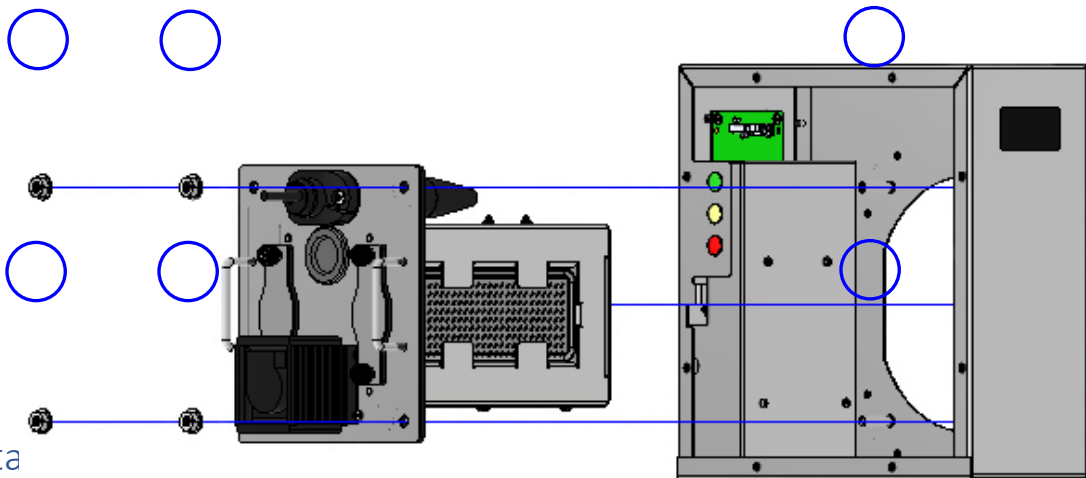

## Insta

1. Place the front cover onto the enclosure.
2. Insert one of the cover screws into its corresponding hole and screw it in loosely.
3. Align the next hole before continuing with the next screw.
4. Tighten all eight screws using a Philips screwdriver.

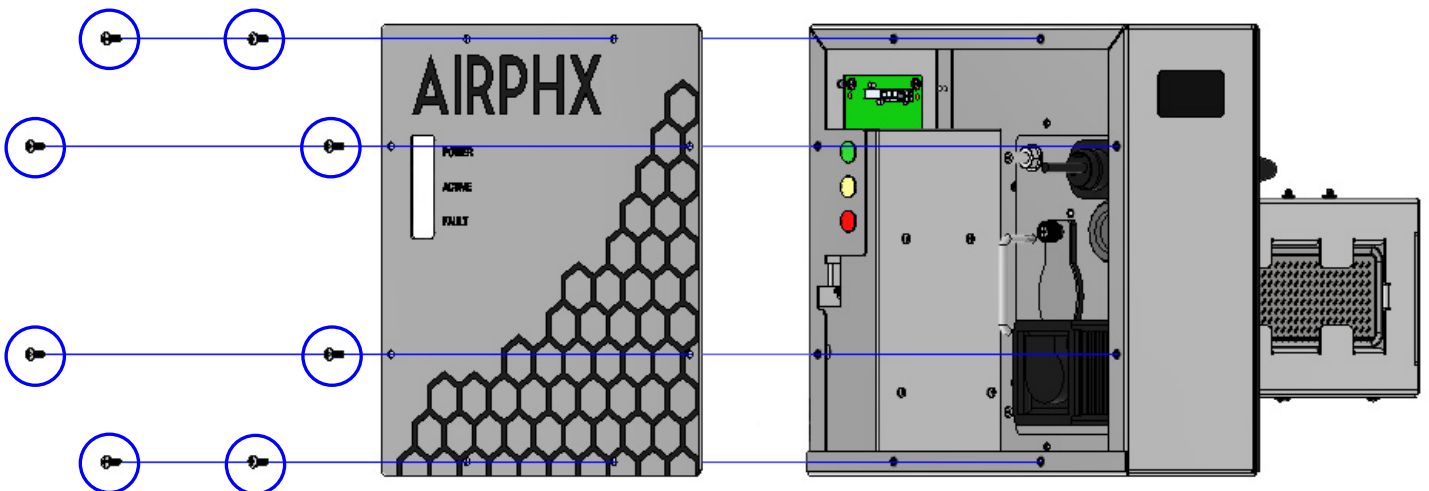

## 10 Modes of Operation

The IDU 250K has two modes of operation.

### Active Mode

In this mode of operation, the IDU 250K will work in conjunction with the fan in your HVAC system. The unit will run continuously, producing oxidizing molecules if sufficient airflow is present. The unit will switch from run to standby mode when airflow stops.

### Standby Mode

In standby mode, the IDU 250K is on, but it is not producing oxidizing molecules.

Conditions that can cause the IDU 250K to go into standby mode:

- Lack of airflow.
- Detection of a fault.
- The HVAC fan is off.

### Fault

The IDU 250K will stop producing oxidizing molecules if a fault is detected.

Conditions that can cause the IDU 250K to go into fault:

- Main circuit board failure.
- Removal of the front cover.

*Note: Solving the fault issue will automatically clear the fault condition allowing the unit to resume operation.*

Fault example:

Powering on the IDU 250K with its cover removed will result in a fault. Replacing the cover will automatically clear the fault. The unit will resume operations once airflow is detected. No further actions are required.

## 11 Operations & Controls

Power the IDU 250K on for the first time:



*WARNING: to avoid the RISK OF ELECTRICAL SHOCK, the IDU 250K should be installed and fully assembled before attempting to operate the unit.*

- Plug the IDU 250K into a 120-volt grounded power outlet and switch on the unit.
  - The green power and yellow active indicators will illuminate\*.
- Once the unit goes through its startup cycle, the yellow active indicator will go off. It will illuminate once airflow is detected.

## 12 Controls/Indicators

### On/Off Switch

The On/Off switch turns the power of the IDU 250K on and off. The power switch is located on the left side of the unit.

Markings on the switch represent the operation of the switch.

I – Indicates ON

O – Indicates Off

## 13 Indicators

The IDU 250K has three indicators on the unit's front cover. Each indicator represents a condition/function and operates independently of each other.

### Power Indicator

The green power Indicator will illuminate when the unit is plugged in and switched on.

### Active Indicator

The yellow active indicator will illuminate once the unit detects the minimal required airflow and is in active mode.

### Fault Indicator

The red fault Indicator will illuminate if a fault is detected.

*\*The IDU 250K has a one-minute startup cycle. During this time, the green and yellow indicators will illuminate. The yellow active indicator will turn off once the startup cycle is complete. It will re-illuminate once airflow is detected.*



# 14 Servicing - Filter Replacement Procedure

It is recommended that the filters are checked every 30 days and replaced if dirty. The filter's life is based on how clean the duct system is and how well it is maintained. Running the IDU 250K with dirty filters will dimension the unit's output.



**WARNING:** To avoid the RISK OF ELECTRICAL SHOCK, turn off and unplug the IDU 250K power cord from the power outlet before servicing.

## Filter Location

- 1. WARNING: Turn off and unplug the IDU 250K.
- 2. Remove the front cover. *Refer to section 7, "Disassembly procedure – Removal of front cover," for more details.*
- 3. With the front cover removed, locate the four thumbscrews on the filter covers. Each filter cover has two. *See fig 1B (below) for more details.*
- 4. Loosen the thumbscrews to remove the cover. *Note: The filter covers will retain the thumbscrews.*

Filter cover Location - Fig. 1B

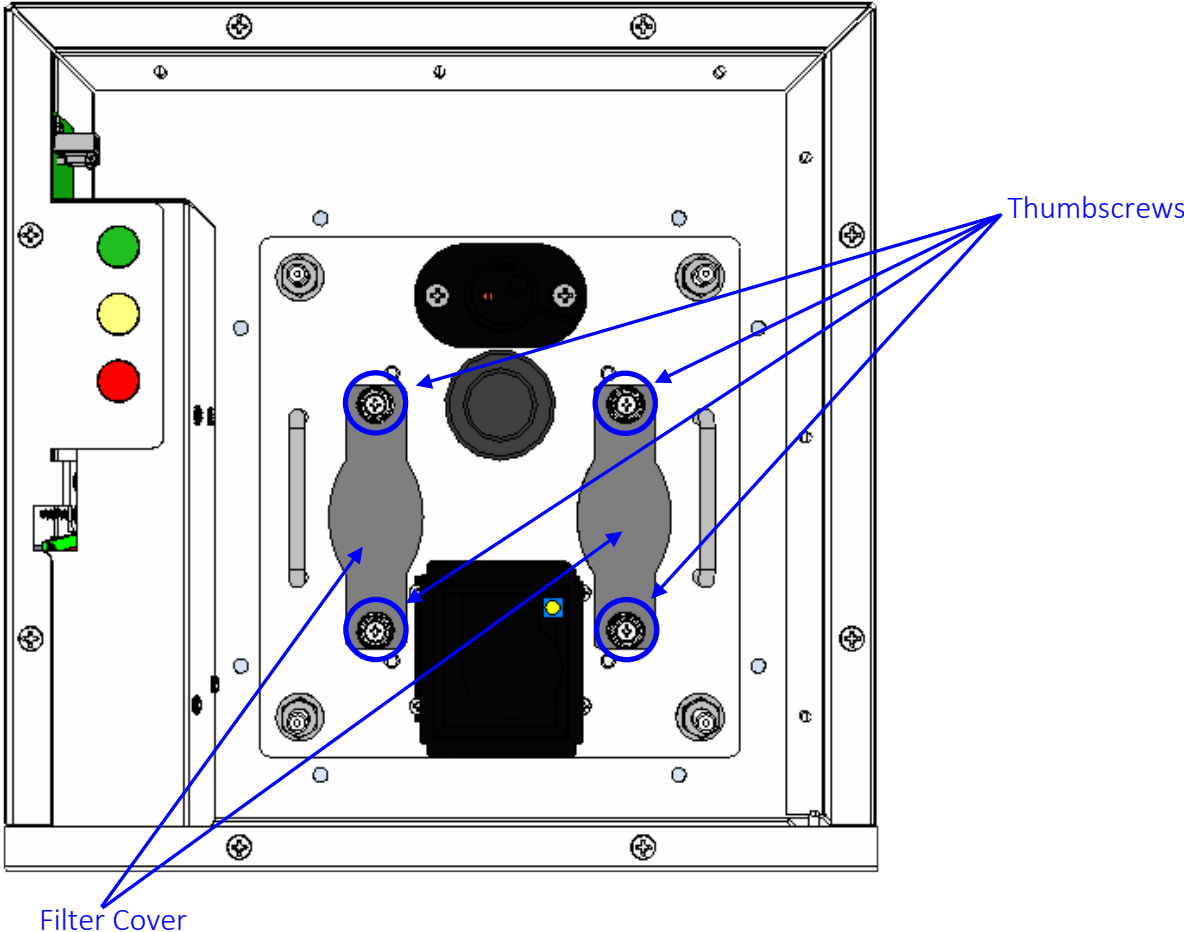

## Removing filters

1. With the filter cover removed, grasp the filter tab, and pull the filter towards you to remove it. *See fig 1C (below) for more details.*
2. Slide the new filter into its slot, ensuring it is fully seated before installing the cover.
3. Secure filter covers in place using the thumbscrews.

Filter Removal - Fig. 1C

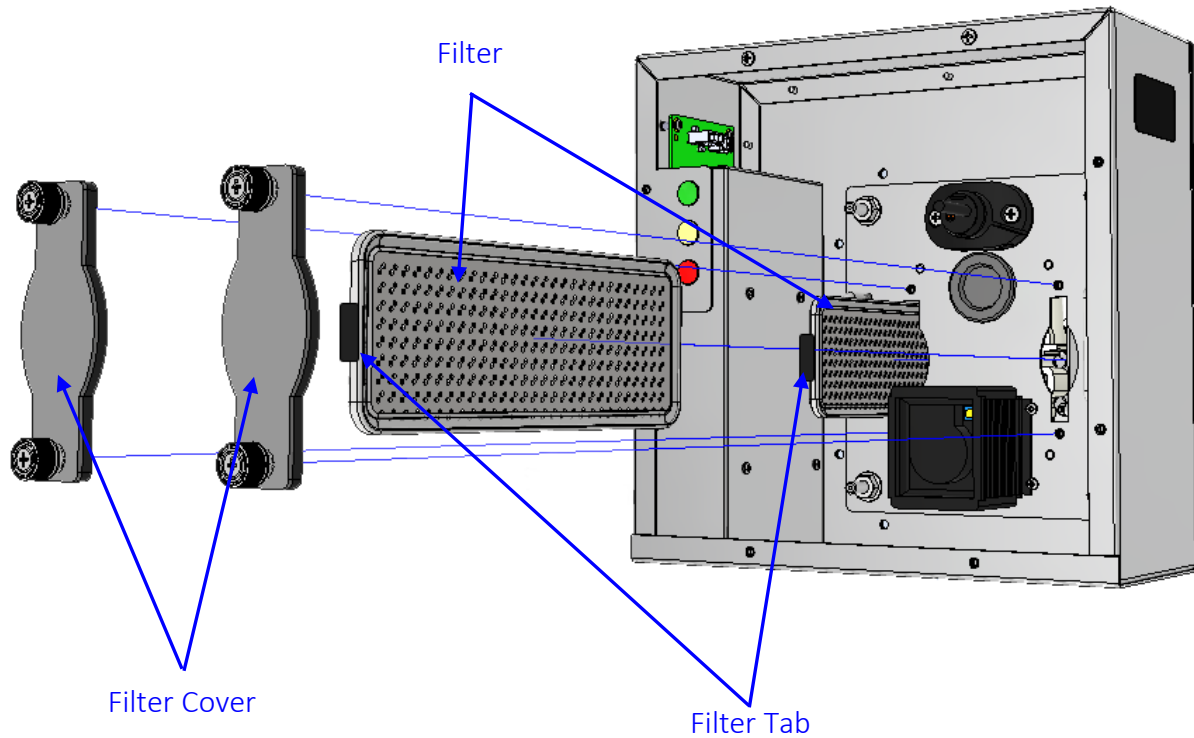

It is recommended that the filters are checked every 30 days and replaced if dirty. The filter's life is based on how clean the duct system is and how well it is maintained. Running the IDU 250K with dirty filters will dimension the unit's output.

## 15 Servicing - Plasma Cell Replacement Procedure

The plasma cell should be replaced every 12 months. Running the IDU 250k with a plasma cell for longer than 12 months will diminish the unit's output.



**WARNING:** To avoid the RISK OF ELECTRICAL SHOCK, turn off and unplug the IDU 250K power cord from the power outlet before servicing.

**CATION:** *The plasma cell contains a glass element and is very fragile. Please handle it with care.*

1. **WARNING:** Turn off and unplug the IDU 250K.
2. Remove the front cover. *Refer to section 7, "Disassembly procedure – Removal of front cover," for more details.*
3. Remove the plasma core. *Refer to section 7, "Disassembly procedure – Removal of plasma core," for more details.*
4. Place the plasma core on a steady surface and remove the six screws that secure the bottom plasma core cover. *See fig 1D (below) for more details.*
5. With the plasma core bottom cover removed, grasp the plasma cell by its pull tabs to remove it from its socket. *See fig 1E (next page) for more details.* Discard old plasma cell.
6. Line the arrow (alignment arrow) on the front finger tab with the front of the plasma core. *See fig 1F (next page) for more details.*
7. Press the plasma cell pins into the sockets within the cradle and press until fully seated. *See fig 1G (page 21) for more details.*
8. Replace the plasma core bottom cover securing it with the six screws previously removed.
9. Carefully insert the plasma core back into the unit, securing it with the four nuts previously removed.
10. Replace the front cover.
11. Plug the IDU 250K in and turn it on. The unit will start up once it completes its startup cycle.

Plasma Core Cover Removal - Fig. 1D

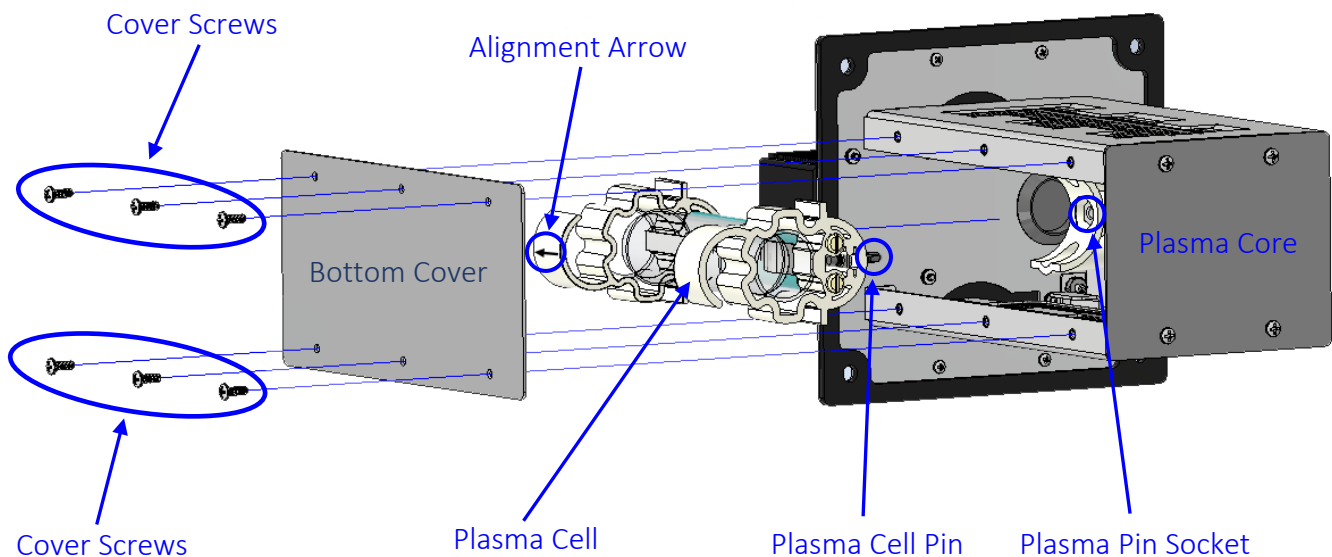

Plasma Cell Removal - Fig. 1E

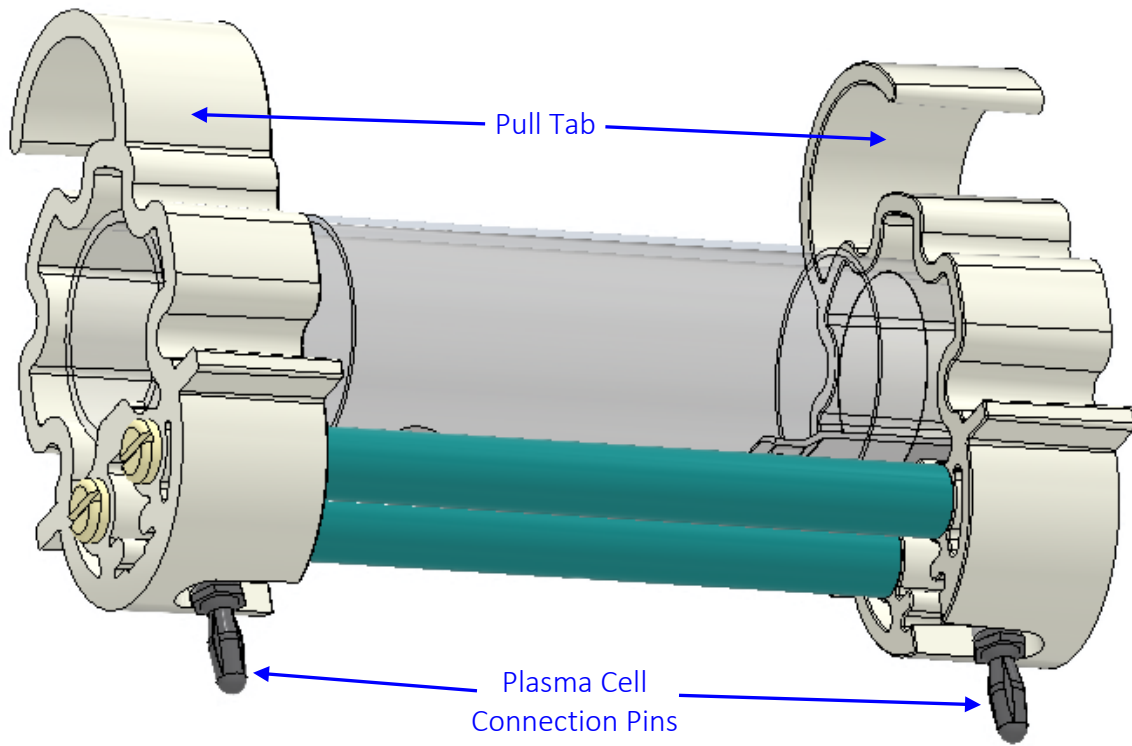

Plasma Cell Replacement - Fig. 1F

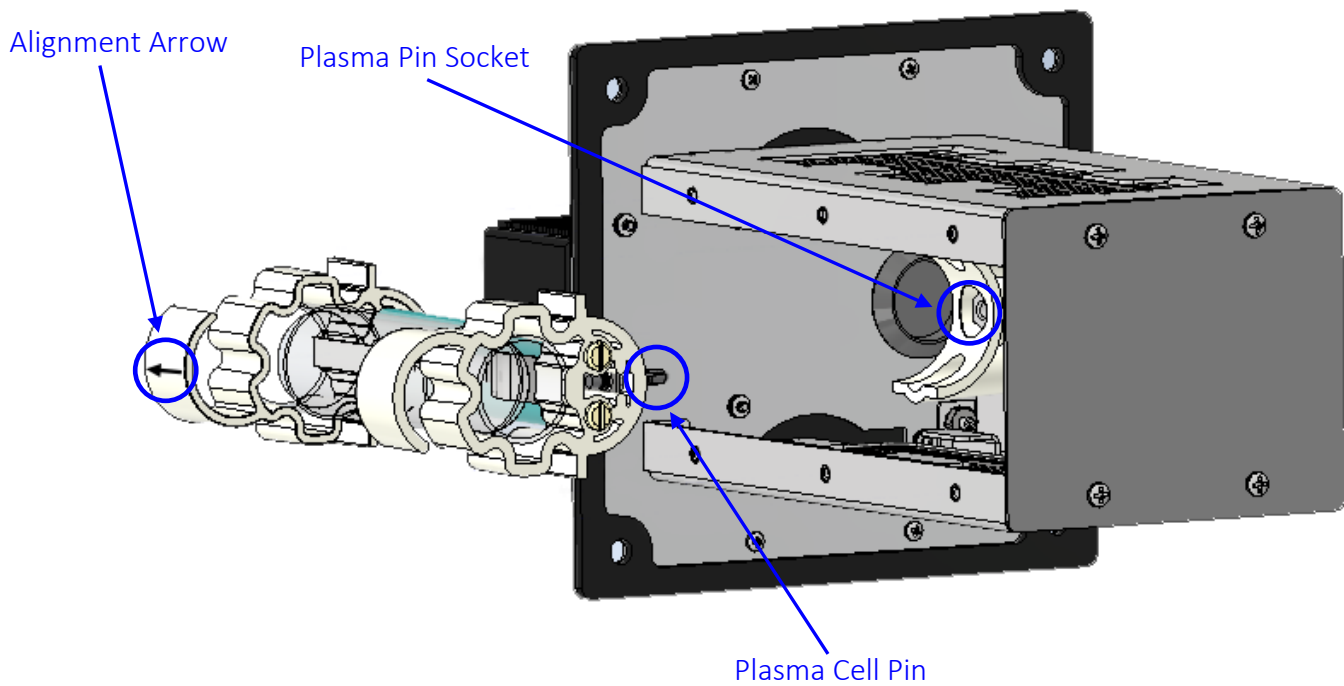

# Plasma Cell Replacement - Fig. 1G

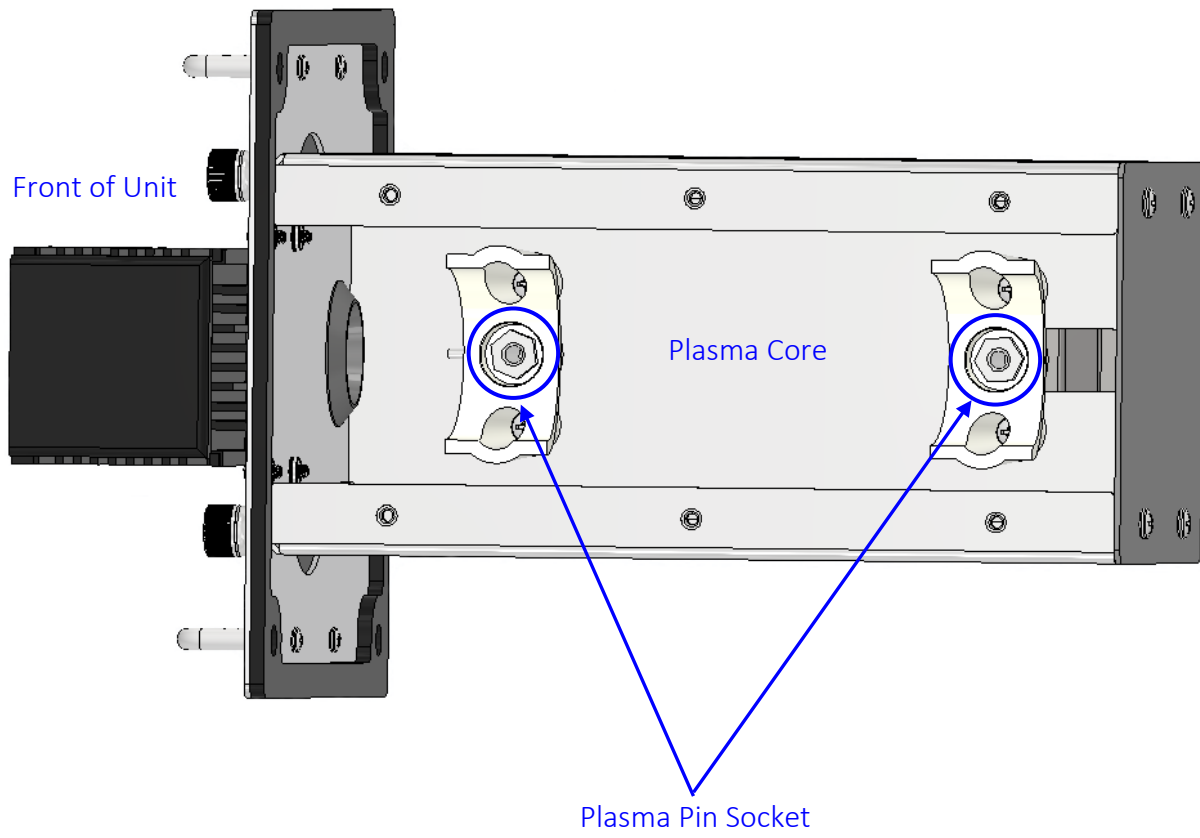

# 16 Indicator Reference Guide

## Standby Mode

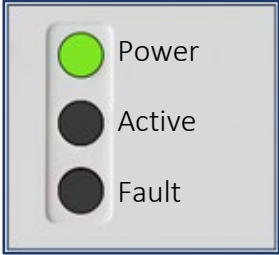

This is an indication that there is power, the IDU 250K is switched on, there is no airflow, and no fault is detected.

## Active Mode

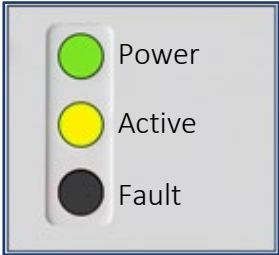

This is an indication that there is power, the IDU 250K is switched on, airflow is detected, and no fault is detected.  
Note: The yellow active indicator will illuminate for one minute during the startup cycle. It will turn off and re-illuminate once airflow is detected.

## Fault Detected

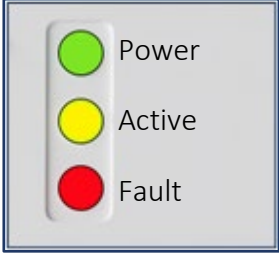

This is an indication that there is power, the IDU 250K is switched on, there is airflow, and a fault was detected.  
Please refer to Section 11 (above) for further details.

# 17 Annunciator Overview (optional)

Included in the box with the IDU 250K is an annunciator for optional use. The annunciator's installation is not required to operate the IDU 250K. The purpose of the annunciator is to give the end user the ability to check the status of the IDU 250K remotely. The annunciator consists of three status indicators that mimic the indicators found on the front of the IDU 250K. Please refer to the *Indicator Reference Guide* section of this guide for more details.

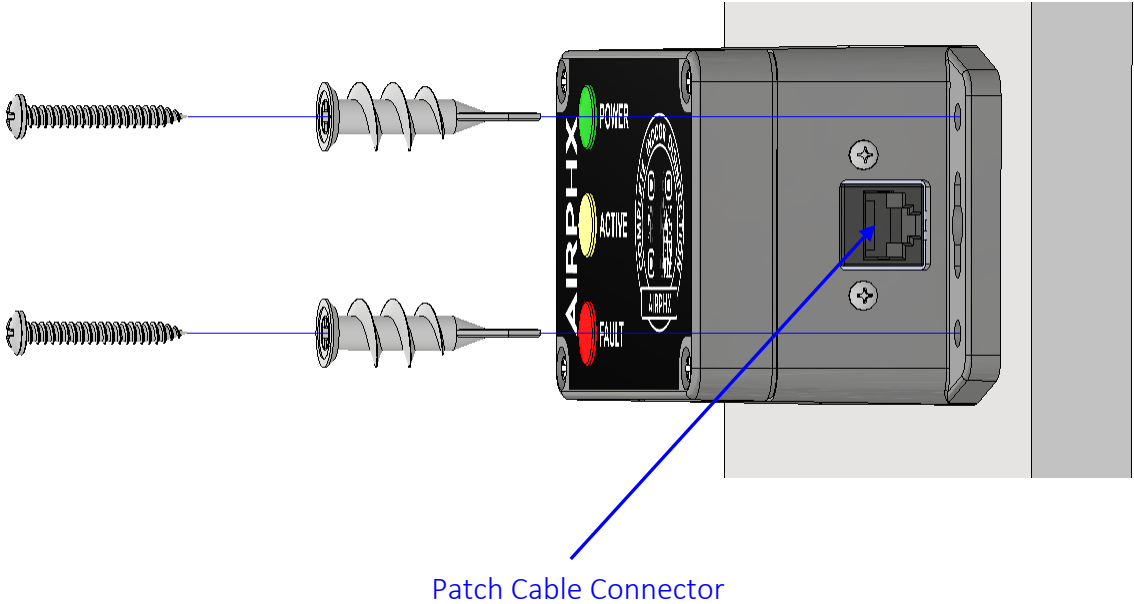
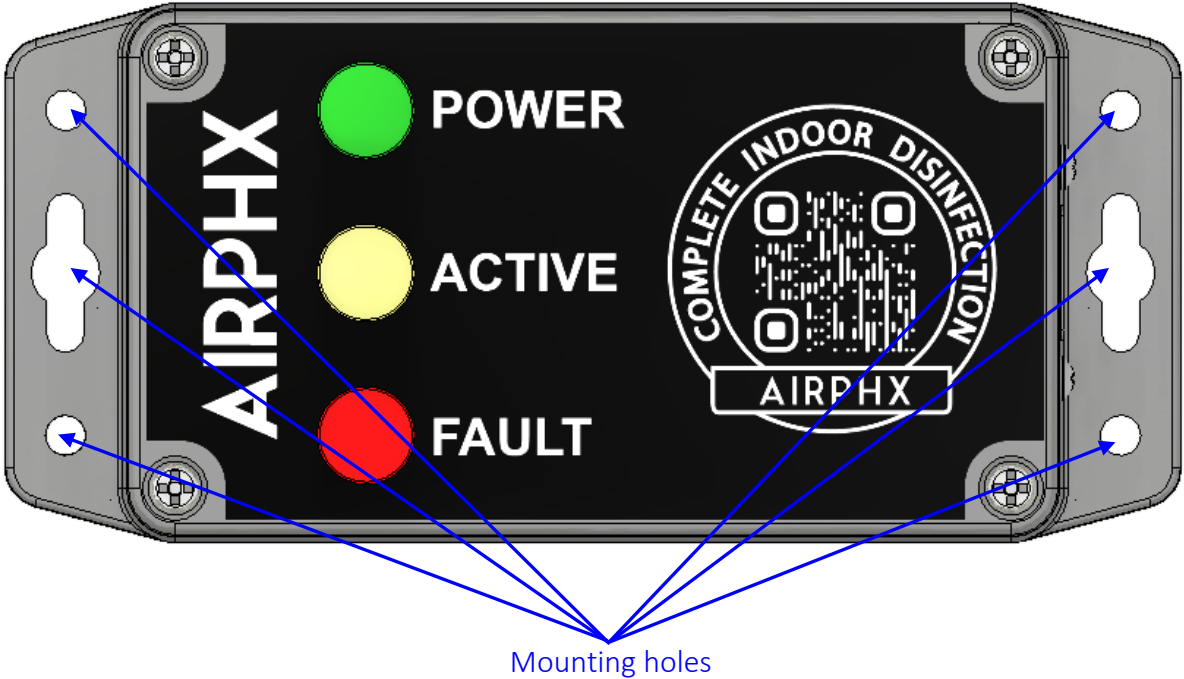

## 18 Annunciator Installation

The annunciator has four mounting holes to secure it to any mounting surface. The annunciator installation kit includes both drywall and concrete anchors with screws.

### Steps

1. Mount the annunciator using the mounting holes located on each side of its baseplate. Please use the proper wall anchors to match the wall to which you affix the annunciator.
2. Run a standard network patch cable from the IDU 250K to the annunciator.

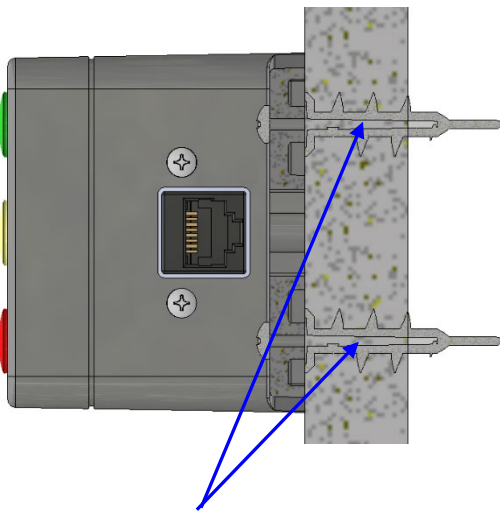

Example of Drywall Anchors

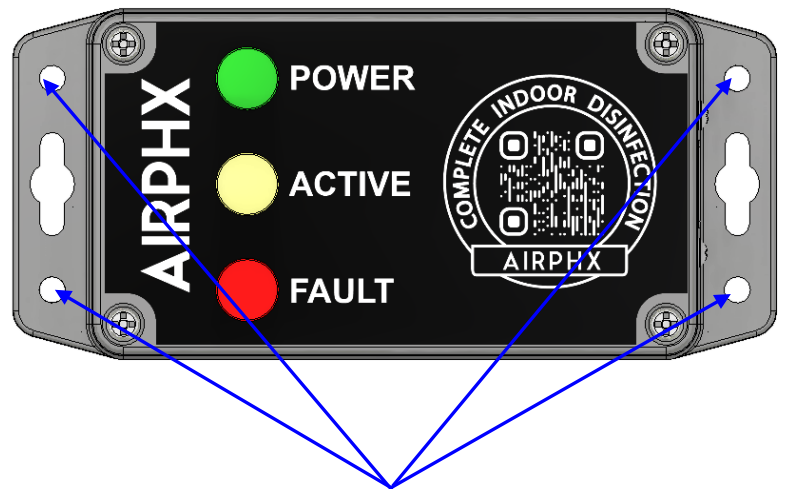

Mounting Holes



Provided Concrete Anchors



Provided Drywall Anchors



## 19 Annunciator Connection

The annunciator connects to the IDU 250k utilizing a standard network patch cable. Please ensure the IDU 250K is off before plugging in the annunciator.

### Steps

1. Run a standard network patch cable that is the proper length (not provided) between the IDU 250K and the annunciator.
2. Plug the patch cable into the network connector on the annunciator's left side.
3. Power off the IDU 250K.
4. Plug the patch cable into the network connector on the right side of the IDU 250K (same side as the AC plug).
5. Power on the IDU 250k. The indicators on the annunciator should illuminate, matching the indicators found on the IDU 250K.
6. Secure the patch cable.

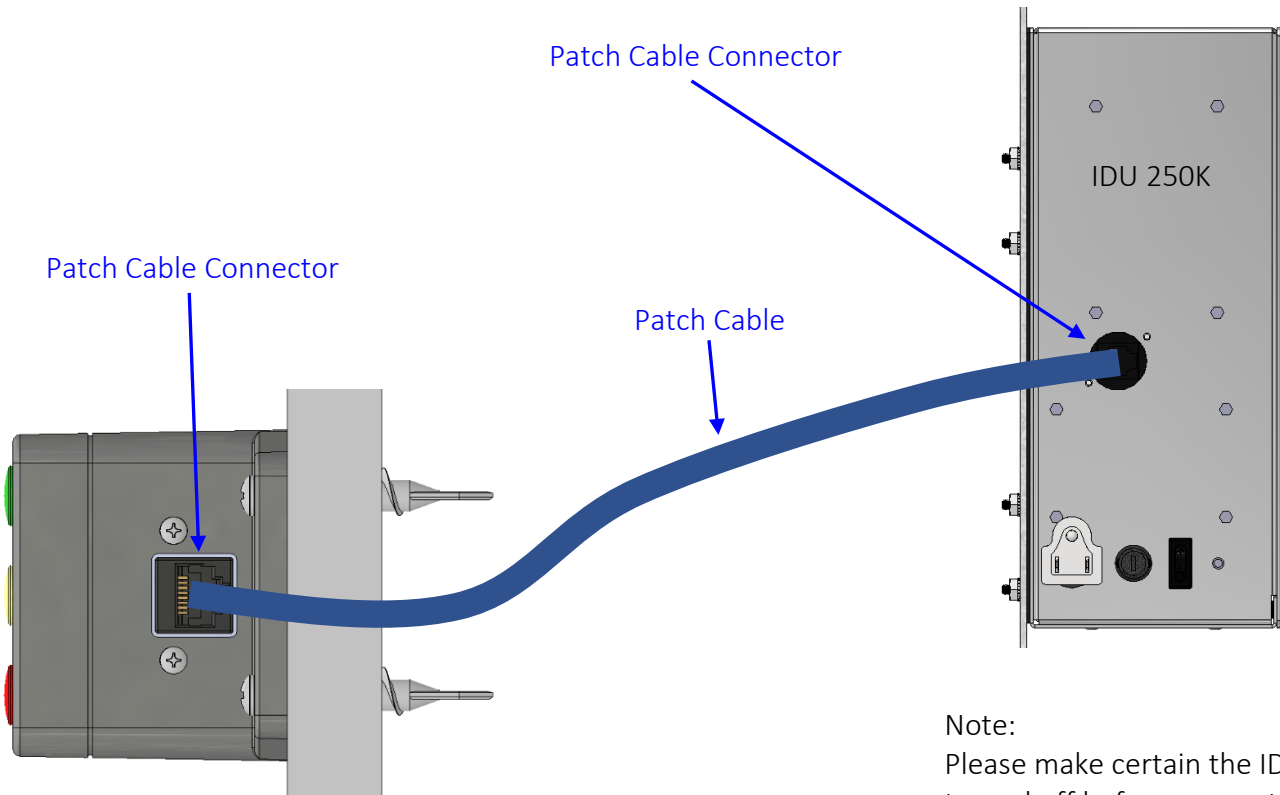

Note:  
Please make certain the IDU 250K is turned off before connecting the annunciator.

## 20 Troubleshooting Guide

Symptom	Action
The green power indicator will not illuminate.	<ol style="list-style-type: none"><li>1. Verify the unit is plugged in and turned on.</li><li>2. Check the power to the outlet.</li><li>3. Check the fuse located next to the power switch. If necessary, replace it with an appropriate fuse.</li></ol>
The yellow indicator will not illuminate.	<ol style="list-style-type: none"><li>1. Check whether the HVAC system is running and airflow is present.</li><li>2. Check if the unit has a fault (illuminated red indicator).</li><li>3. Check the airflow of your system. The minimum required airflow is 200 LFM (linear feet per minute).</li><li>4. A startup cycle may take one minute before airflow is detected.</li></ol>
There is a fault with the unit (illuminated red indicator).	<ol style="list-style-type: none"><li>1. Make sure the front cover is secure.</li><li>2. The unit may have a main circuit board fault.</li><li>3. Make a note of the status of the other indicators and call the AIRPHX service department at 888.263.3882.</li></ol>

---

*If further assistance is required, please contact your AIRPHX representative at 855- 424-7749 or visit our website <https://www.airphx.com/FAQs>, where additional information can be found, including user guides as well as helpful videos.*

---

## 21 Frequently asked questions

A number of frequently asked questions about the IDU 250K may be found at [www.airphx.com/FAQs](http://www.airphx.com/FAQs). Some questions concerning operations are set forth below.

Q – I have plugged the IDU 250K into a 120-volt outlet, but the unit will not turn on. What should I do?

A – Verify that the outlet has power and the outlet has the correct voltage.

Q – I powered the IDU 250K on for the first time, and the yellow active was illuminated but then went off. What do I do?

A – The IDU 250K has a one-minute startup cycle when first turned on. Both the green power and yellow active indicator will illuminate. After one minute, the yellow active indicator will turn off until airflow is detected.

Q – What should I do if the red fault indicator is illuminated?

A – Check to see if the front cover is secure. If it is in place and secure, contact the AIRPHX service department at 888.263.3882.

Q – How often do I need to change the filter on the IDU 250K?

A – The filter should be checked every 30 days and changed if dirty unless otherwise specified.

For further information, please refer to the section in this guide, *Filter Replacement Procedure*.

*Note: The frequency of replacing the filter depends on the HVAC's maintenance.*

Q – How often do I need to change the plasma cell on the IDU 250K?

A – Annually.

Q – What is standby?

A – In standby mode, the IDU 250K is not producing oxidizing molecules. The unit is running and waiting for airflow.

Conditions that can cause the IDU 250K to go into standby:

- The HVAC system is off.
- The unit has not detected the minimum required airflow.
- The unit has detected a fault.

Q – Where is the IDU 250K manufactured?

A – The IDU 250K is manufactured in the United States.

## 22 Frequently asked questions cont.

Q – Is the annunciator required for the IDU 250K to operate?

A – No. The annunciator is an option and is not required to operate the IDU 250K properly.

Q – What should I do if the indicators on the annunciator do not illuminate?

A – Please check the following.

- Check the patch cable connection to the annunciator.
- Check the patch cable connection to the IDU 250K.
- Check that the IDU 250K is on and operating.
- Ensure the patch you use is a standard network patch cable, not a crossover patch cable.

Q – What do I do if the indicators on the annunciator do not match the indicators on the IDU 250K?

A – Call our service department for a replacement annunciator.

Q – Does the annunciator require any maintenance?

A – No.

Q – Does the annunciator require power?

A – No. The IDU 250K provides power to the annunciator.

Q – Is the annunciator waterproof?

A – No.

Q – Can the annunciator mount in a dusty environment?

A – Yes.

Q – Can the annunciator be mounted to concrete?

A – Yes. Please use the proper mounting anchors.

## Warranty

PRODUCT WARRANTY. 1 YEAR ON ALL PARTS; 1 YEAR ON LABOR FROM THE DATE OF PURCHASER INVOICE. AT AIRPHX'S OPTION, AIRPHX MAY REPAIR OR REPLACE THE PRODUCT.

PHOENIXAIRE, LLC (dba AIRPHX) EXPRESSLY WARRANTS ALL NEW PRODUCTS TO BE FREE FROM DEFECTS IN MATERIALS AND MANUFACTURE FOR THE WARRANTY PERIODS SET FORTH ABOVE. THE WARRANTY PERIOD COMMENCES ON THE INVOICE DATE ON THE ORIGINAL PURCHASE. THIS WARRANTY APPLIES ONLY AGAINST DEFECTS DISCOVERED WITHIN THE WARRANTY PERIOD AND EXTENDS ONLY TO THE ORIGINAL PURCHASER OF THE PRODUCT. ONLY PARTS, REPAIRS, MODIFICATION AND/OR MAINTENANCE SUPPLIED BY AN AIRPHX REPRESENTATIVE, UNDER THE TERMS OF THIS WARRANTY, WILL BE WARRANTED FOR THE REMAINDER OF THE ORIGINAL WARRANTY PERIOD. TO PROCESS A CLAIM UNDER THIS WARRANTY, THE PURCHASER MUST NOTIFY AIRPHX IN WRITING OR BY FAX WITHIN 30 DAYS AFTER THE DISCOVERY OF THE ALLEGED DEFECT AND MAKE THE PRODUCT AVAILABLE FOR INSPECTION BY AN AIRPHX REPRESENTATIVE. FAILURE TO TIMELY AND PROPERLY NOTIFY AIRPHX IN WRITING OR BY FAX WILL RESULT IN NULLIFICATION OF THIS WARRANTY.

ANY PARTS, REPAIRS, MODIFICATION AND/OR MAINTENANCE SUPPLIED BY A NON-AIRPHX REPRESENTATIVE (OTHER THAN AIRPHX RECOMMENDED ROUTINE MAINTENANCE) VOIDS THE ENTIRE WARRANTY FOR THIS DEVICE.

NO OTHER EXPRESS WARRANTY IS GIVEN WITH THE PURCHASE ORDER AND AIRPHX DISCLAIMS ANY AUTHORITY FOR ANY EMPLOYEE OR AGENT TO PROVIDE OR MAKE ANY OTHER WARRANTY OF ANY KIND WHETHER IN WRITING OR ORALLY.

This warranty is valid only in accordance with the conditions set forth below:

1. The warranty applies to the AIRPHX product only while
  - a. Title and possession remain in the original purchaser and proof of purchase is demonstrated,
  - b. It has not been subjected to casualty, misuse, abuse, service, or modification performed and not authorized by an AIRPHX representative,
  - c. Claims are made timely and properly within the warranty period by written notice or fax (within 15 days of the applicable warranty period).
2. This warranty does not cover damage or equipment failure caused by any type of electrical surge and/or failure to adhere to AIRPHX Operating Instructions and Care and Cleaning Instructions.
3. Except in Canada, AIRPHX does not pay labor outside of the United States.
4. Warranties outside the United States and Canada may vary. Please contact your local Dealer for details.

This limited warranty shall not apply to:

1. Cosmetic items.
2. Repairs performed on AIRPHX equipment missing a serial number or with a serial tag that has been altered or defaced.
3. Service calls to correct installation of the equipment or instruct the owners on how to use the equipment.
4. Pickup, delivery, or freight charges involved with repairs.
5. Any labor costs incurred beyond the applicable labor warranty period.
6. Any equipment that has had the end caps removed by any person other than an AIRPHX representative.

## Disclaimer

The express warranties provided herein are the exclusive warranties given by AIRPHX and supercede any prior, contrary or additional representation/warranties, written or oral. ANY IMPLIED WARRANTIES, INCLUDING THE WARRANTY OF MERCHANTABILITY AND/OR FITNESS FOR A PARTICULAR PURPOSE THAT APPLY TO ANY PARTS DESCRIBED ABOVE ARE LIMITED IN DURATION TO THE PERIODS OF EXPRESS WARRANTIES GIVEN ABOVE FOR THOSE SAME PARTS. AIRPHX HEREBY DISCLAIMS AND EXCLUDES THOSE WARRANTIES THEREAFTER. SOME STATES DO NOT ALLOW LIMITATION ON HOW LONG AN IMPLIED WARRANTY LASTS, SO THE ABOVE LIMITATION MAY NOT APPLY TO YOU. AIRPHX ALSO HEREBY DISCLAIMS AND EXCLUDES ALL OTHER OBLIGATIONS OR LIABILITIES, EXPRESS OR IMPLIED ARISING BY LAW OR OTHERWISE WITH REGARD TO ANY NONCONFORMANCE OR DEFECT IN ANY PRODUCT, INCLUDING BUT NOT LIMITED TO: (A) ANY OBLIGATION, LIABILITY, RIGHT, CLAIM, OR REMEDY IN TORT, WHETHER OR NOT ARISING FROM THE NEGLIGENCE OF AIRPHX OR ITS SUPPLIERS (WHETHER ACTIVE, PASSIVE OR IMPUTED) AND (B) ANY OBLIGATION, LIABILITY, RIGHT, CLAIM OR REMEDY FOR LOSS OF OR DAMAGE TO ANY EQUIPMENT. THIS DISCLAIMER AND RELEASE SHALL APPLY EVEN IF THE EXPRESS WARRANTY SET FORTH ABOVE FAILS IN ITS ESSENTIAL PURPOSE.

### Exclusive Remedies

For any product described above that fails to conform to its warranty, an AIRPHX representative will exclusively provide repairs provided the equipment has not been subject to casualty, misuse, abuse, service or modification performed and not authorized by an AIRPHX representative. Service must be obtained by calling AIRPHX at 1 (855) 4 AIRPHX / 1 (855) 424-7749. THESE SHALL BE THE SOLE AND EXCLUSIVE REMEDIES OF THE BUYER FOR ANY BREACH OF WARRANTY.

AIRPHX AND/OR ITS SUPPLIERS, DEALERS AND DISTRIBUTORS SHALL HAVE NO OBLIGATION OR LIABILITY, WHETHER ARISING IN CONTRACT (INCLUDING WARRANTY), TORT (INCLUDING ACTIVE, PASSIVE, OR IMPUTED NEGLIGENCE AND STRICT LIABILITY), OR OTHERWISE, FOR DAMAGE TO THE EQUIPMENT, PROPERTY DAMAGE, LOSS OF USE, REVENUE OR PROFIT, COST OF CAPITAL, COST OF SUBSTITUTE EQUIPMENT, ADDITIONAL COSTS INCURRED BY BUYER (BY WAY OF CORRECTION OR OTHERWISE) OR ANY OTHER INCIDENTAL, SPECIAL, INDIRECT, OR CONSEQUENTIAL DAMAGES, WHETHER RESULTING FROM NON-DELIVERY OR FROM THE USE, MISUSE OR INABILITY TO USE THE PRODUCT. THIS EXCLUSION APPLIES EVEN IF THE ABOVE WARRANTY FAILS OF ITS ESSENTIAL PURPOSE AND REGARDLESS OF WHETHER SUCH DAMAGES ARE SOUGHT FOR BREACH OF WARRANTY, BREACH OF CONTRACT, NEGLIGENCE, OR STRICT LIABILITY IN TORT OR UNDER ANY OTHER LEGAL THEORY.